

LEAD ACID (AGM) BATTERY

MR9-12

Marvel MR series is a general-purpose battery with 6~8 years design life in float service. It meets with IEC, JIS, BS, GB/T AND YD/T standards. With advanced AGM valve regulated technology and high purity raw material. The Marvel MR series battery maintains high consistency for better performance and reliable standby service life. It is suitable for UPS/EPS, medical equipment, emergency light and security system applications.



MADE IN VIETNAM / CHINA



SPECIFICATION

Cells Per Unit	6
Voltage Per Unit	12
Nominal Capacity	9Ah@20hour-rate to 1.75V per cell @25 °C
Weight	Approx. 2.30 Kg (Tolerance± 5.0%)
Internal Resistance	Approx. 22 mΩ
Terminal	F1/F2
Max. Discharge Current	90A (5 sec)
Short Circuit Current	450A
Design Life	6~8 years (Float charging)
Max. Charging Current	2.7 A
Reference Capacity	C3 6.96AH C5 7.85AH C10 8.41AH C20 9.00AH
Standby Use Voltage	13.7 V~13.9 V @ 25°C Temperature Compensation: -3mV/°C/Cell
Cycle Use Voltage	14.6 V~14.8 V @ 25°C Temperature Compensation: -4mV/°C/Cell
Operating Temperature Range	Discharge: -20°C~60°C Charge: 0°C~50°C Storage: -20°C~60°C
Normal Operating Temperature Range	25°C± 5°C
Self Discharge	RITAR Valve Regulated Lead Acid (VRLA) batteries can be stored for up to 6 months at 25°C and then recharging is recommended. Monthly Self-discharge ratio is less than 3% at 25°C. Please charge batteries before using.
Container Material	A.B.S. UL94-HB, UL94-V0 Optional.

Dimensions

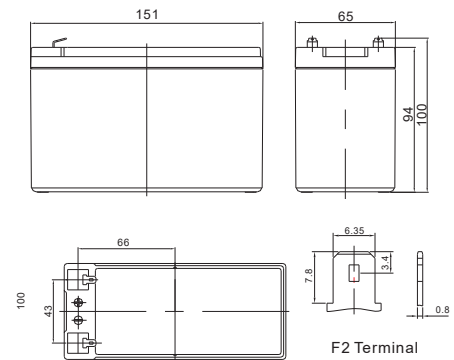

Length	151±1.5mm (5.94 inches)
Width	65±1.5mm (2.56 inches)
Height	94±1.5mm (3.70 inches)
Total Height	100±1.5mm (3.94 inches)
Terminal	Value
M5	6~7 N*m
M6	8~10 N*m
M8	10~12 N*m

Constant Current Discharge Characteristics :A(25°C)

F.V/Time	5MIN	10MIN	15MIN	30MIN	1HR	2HR	3HR	4HR	5HR	8HR	10HR	20HR
1.60V	35.17	24.62	17.62	10.12	5.499	3.376	2.538	2.049	1.698	1.093	0.887	0.469
1.65V	32.71	23.26	16.85	9.716	5.310	3.268	2.460	1.994	1.654	1.080	0.877	0.461
1.70V	29.51	21.41	15.78	9.287	5.137	3.161	2.393	1.939	1.611	1.064	0.863	0.456
1.75V	26.44	19.60	14.68	8.876	4.950	3.050	2.321	1.890	1.570	1.049	0.852	0.450
1.80V	23.21	17.74	13.56	8.484	4.760	2.941	2.250	1.835	1.530	1.031	0.841	0.446
1.85V	18.43	14.50	11.25	7.307	4.270	2.695	2.080	1.706	1.426	0.968	0.792	0.423

Constant Power Discharge Characteristics :WPC(25°C)

F.V/Time	5MIN	10MIN	15MIN	30MIN	1HR	2HR	3HR	4HR	5HR	8HR	10HR	20HR
1.60V	58.30	41.84	30.80	18.38	10.33	6.399	4.848	3.934	3.273	2.134	1.744	0.923
1.65V	54.85	40.30	29.89	17.83	10.04	6.225	4.718	3.842	3.200	2.114	1.726	0.909
1.70V	50.61	37.78	28.41	17.22	9.770	6.053	4.610	3.751	3.127	2.087	1.702	0.899
1.75V	46.35	35.21	26.82	16.62	9.470	5.868	4.491	3.669	3.059	2.062	1.681	0.890
1.80V	41.57	32.43	25.12	16.05	9.161	5.687	4.369	3.577	2.991	2.031	1.662	0.882
1.85V	33.69	26.97	21.14	13.96	8.267	5.239	4.057	3.337	2.798	1.911	1.567	0.838

(Note) The above characteristics data are average values obtained within three charge/discharge cycle not the minimum values. The battery must be fully charged before the capacity test. The Cm should reach 95% after the first cycle and 100% after the third cycle.

Discharge Characteristics Curve

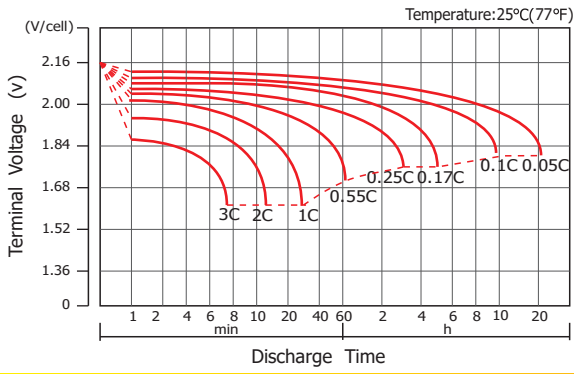

Charge Characteristic Curve For Standby Use

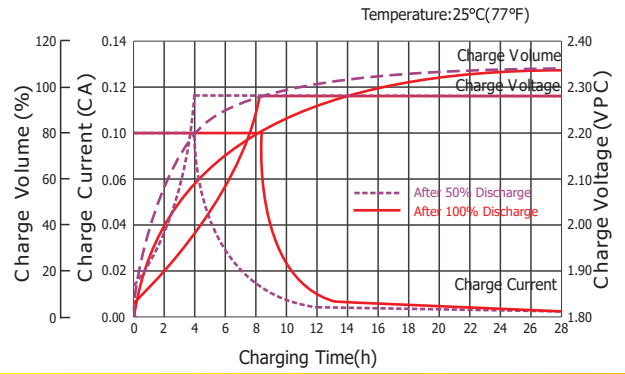

Cycle Life In Relation To Depth Of Discharge

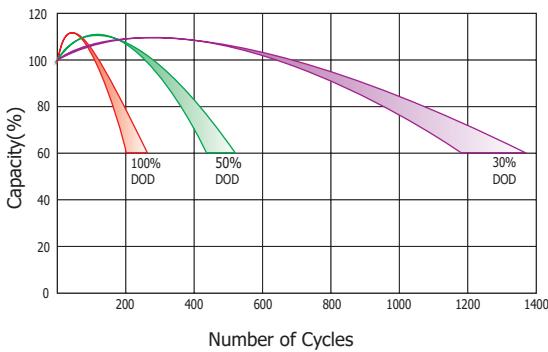

Relationship Between Charging Voltage And Temperature

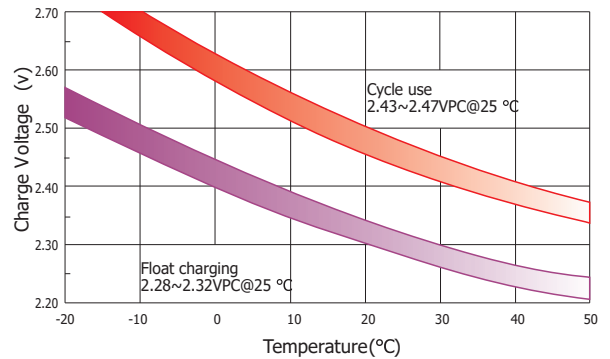

Temperature Effects On Capacity

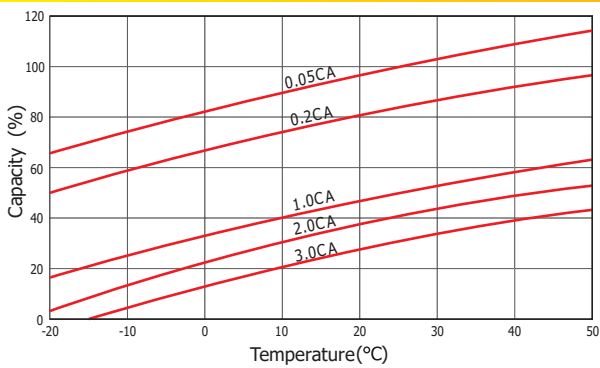

Storage Characteristics

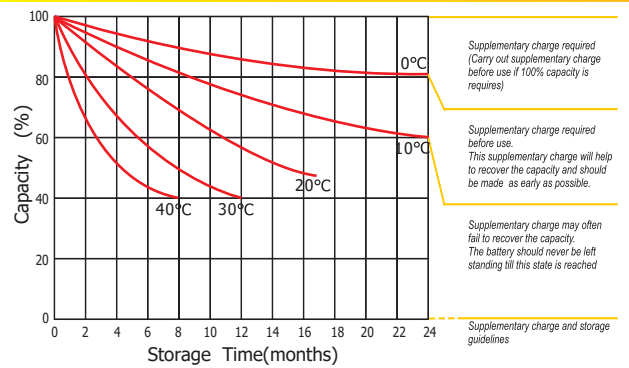

Effect Of Temperature On Long Term Life

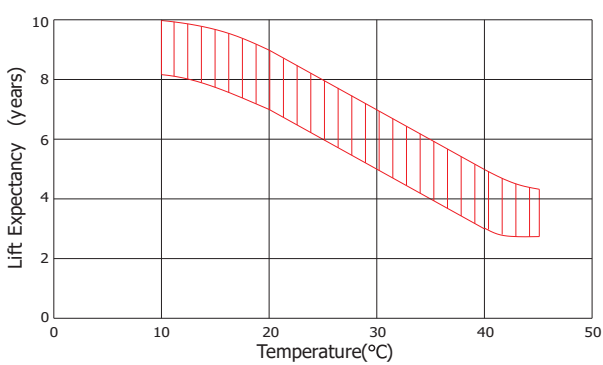

Life Characteristics Of Standby Use

